

Service Manual

THE FISHER®

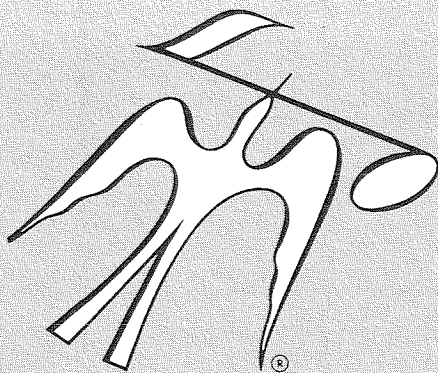
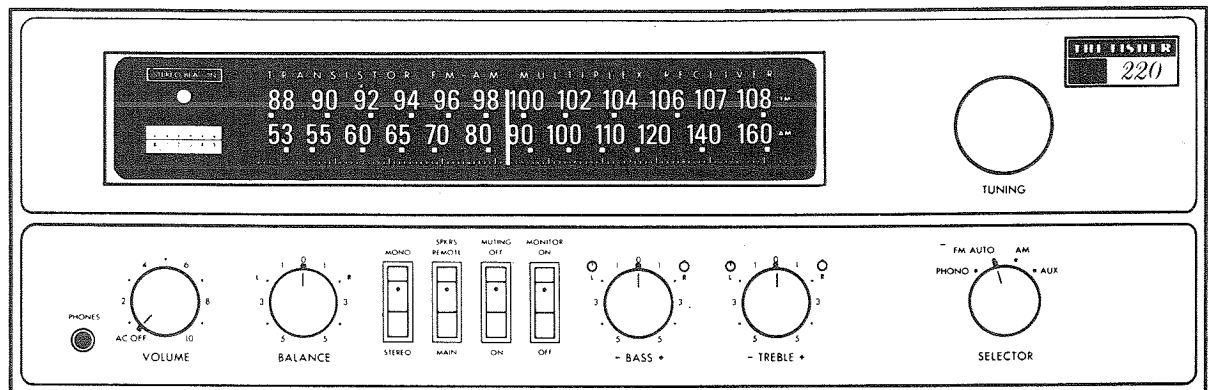

220-T

\$1.00

CHASSIS SERIAL NUMBERS

BEGINNING 10001

FISHER RADIO • LONG ISLAND CITY • NEW YORK 11101

CAUTION: This is a FISHER precision high-fidelity instrument. It should be serviced only by qualified personnel — trained in the repair of transistor equipment and printed circuitry.

TEST EQUIPMENT REQUIRED

The following are needed to completely test and align modern high-fidelity instruments such as amplifiers, tuners and receivers.

Vacuum-Tube Voltohmmeter (100-mV DC scale)	10.7-MHz Sweep Generator
Audio Vacuum-Tube Voltmeter (10-mV AC scale)	455-kHz Sweep Generator
Oscilloscope (Flat to 100 kHz Minimum)	Line Voltage Autotransformer or Voltage Regulator
Audio (Sine-Wave) Generator	2 — Load Resistors, 4 or 8 Ohm, 50 Watt
Intermodulation Distortion Analyzer	2 — Full Range Speakers for Listening Tests
Harmonic Distortion Analyzer	Stereo Source — Turntable or Tape Recorder for Listening Tests
AM/FM Signal Generator	Soldering Iron with Small Tip
Multiplex Generator (preferably with RF output — FISHER Model 300 or equal)	Fully Insulated from Power Line
	Suction Desoldering Tool

PRECAUTIONS

Many of these items are included just as a reminder—they are normal procedures for experienced technicians. Shortcuts can be taken but often they cause additional damage—to transistors, circuit components or the printed-circuit board.

Soldering—A well-tinned, hot, clean soldering iron tip will make it easier to solder without damage to the printed-circuit board or the many circuit components mounted on it. It is not the wattage of the iron that counts—it is the heat available at the tip. Some 50-watt irons reach temperatures of 1,000° F—others will hardly melt solder. Small-diameter tips should be used for single solder connections—larger pyramid and chisel tips are needed for larger areas.

- When removing defective resistors, capacitors, etc., the leads should be cut as close to the body of the circuit component as possible. (If the part is not being returned for in-warranty factory replacement it may be cut in half—with diagonal-cutting pliers—to make removal easier.)

- Special de-soldering tips are made for unsoldering multiple-terminal units like IF transformers and electrolytic capacitors. By unsoldering all terminals at the same time the part can be removed with little chance of breaking the printed-circuit board.

- Always disconnect the chassis from the power line when soldering. Turning the power switch OFF is not enough. Power-line leakage paths, through the heating element, can destroy transistors.

Transistors—Never attempt to do any work on the transistor amplifiers without first disconnecting the AC linecord and waiting until the power supply filter-capacitors have discharged.

- Guard against shorts—it takes only an instant for a base-to-collector short to destroy that transistor and possibly others direct-coupled to it. (In the time it takes for a dropped machine screw, washer or even the screwdriver, to glance off a pair of socket terminals (or between a terminal and the chassis) a transistor can be ruined.)

- DO NOT bias the base of any transistor to, or near, the same voltage applied to its collector.

- DO NOT use an ohmmeter for testing transistors. The voltage applied through the test probes may be higher than the base-emitter breakdown voltage of the transistor.

Output Stage and Driver — Replacements for output and

driver transistors, if necessary, must be made from the same beta group as the original type. The beta group is indicated by a colored dot on the mounting flange of the transistor. Be sure to include this information, when ordering replacement transistors.

- If one output transistor burns out (open or shorts), always remove ALL output transistors in that channel and check the bias adjustment, the control and other parts in the network with an ohmmeter before inserting a new transistor. All output transistors in one channel will be destroyed if the base-biasing circuit is open on the emitter end.

- When mounting a replacement power transistor be sure the bottom of the flange, the mica insulator and the surface of the heat sink are free of foreign matter. Dust and grit can prevent perfect contact reducing heat transfer to the heat sink. Metallic particles can puncture the insulator and cause shorts—ruining the transistor.

- Silicone grease must be used between the transistor and the mica insulator and between the mica and the heat sink for best heat conduction. (Use Dow-Corning DC-3 or C20194 or equivalent compounds made for power transistor heat conduction.)

- Use care when making connections to speakers and output terminals. Any frayed wire ends can cause shorts that may burn out the output transistors—they are direct-coupled to the speakers. To reduce the possibility of shorts at the speakers, lugs should be used on the exposed ends or at least the ends of the stranded wires should be tinned to prevent frayed wire ends. The current in the speakers and output circuitry is quite high. Poor contacts or small size wire can cause power losses in the speaker system. Use 14 or 16 AWG for long runs of speaker wiring.

Voltage Measurements—Voltage measurements are made with the line voltage adjusted to 117 volts and all readings are $\pm 10\%$. All voltages are DC, measured with a VTVM to ground, with no signal input unless otherwise noted. indicates 1-kHz audio voltages, measured with an audio AC VTVM to ground at various points from the phono input to the power amplifier output.

Alignment Procedures—Replacement of transistors and components in the front end, IF amplifier and multiplex decoder will normally not require realignment of these circuits. Realignment of these circuits, unless absolutely necessary, is not recommended. Do not attempt a realignment unless the required test equipment is available and the alignment procedure is thoroughly understood.

BECAUSE ITS PRODUCTS ARE SUBJECT TO CONTINUOUS IMPROVEMENT, FISHER RADIO CORPORATION RESERVES THE RIGHT TO MODIFY ANY DESIGN OR SPECIFICATION WITHOUT NOTICE AND WITHOUT INCURRING ANY OBLIGATION.

SERVICE PROCEDURES

DIAL STRINGING

- Remove dial pointer.
 - Lift out left dial glass lamp and remove screw holding left side of dial glass panel.
 - Remove two screws holding right side of dial glass panel.
 - Pull dial glass panel towards left and tilt the panel down as far as the leads allow.
 - Rotate the tuning capacitor drive drum to its maximum counter-clockwise position.
 - Tie end of dial cord to the end of small spring A. Fasten spring to ear inside the drive drum (Figure 1).
 - Run the dial cord through the slot in the rim of the drive drum and set in the underside of groove 1 (side view).
 - Pull dial cord taut and wrap 1½ turns around the flywheel shaft.
 - Rotate the tuning capacitor drive drum to its maximum clockwise position, allowing the dial cord to follow the grooves in the drive drum (Figure 2). Keep the dial cord taut during this procedure.
 - Guide the dial cord over the top of the drive drum and place it in groove 3 (top view).
 - Run the dial cord through the slot in the drive drum and bring it under and around the beveled washer. Pull the dial cord taut and tighten the machine screw to hold the dial cord under the washer.
 - Rotate tuning capacitor drive drum to its maximum counter-clockwise position.
 - Run loose end of dial cord out through the slot in the drive drum and place it in groove 3 (Figure 3). Guide the dial cord through pulleys A and B.
 - Rotate the tuning capacitor drive drum to its maximum clockwise position. Keep the dial cord taut during this procedure.
 - Guide the dial cord under the drive drum into groove 5 (Figure 4). Bring the dial cord up and around groove 6 and into the slot in the drive drum.
- NOTE: Check that there is an empty groove between this turn and the next to last turn of dial cord on the drum.
- Loosen the machine screw. Pull the dial cord taut until adjusting spring B stretches open and pulley bracket A stands straight up. Place the cord under the beveled washer and tighten the machine screw.
- CAUTION: Do not disturb dial cord already placed under the washer.
- Replace the dial glass panel using the first three steps in reverse order.
 - Replace the dial pointer on the top of the dial glass panel.

REPLACING METER LAMP

- Disconnect AC power cord.
- Remove screws which hold top cover to the chassis and lift off the top cover.
- Gently push in on the lamp and turn it counterclockwise to remove. Remove the metal lamp shade and place it on the new lamp in the same position. Place the new lamp in the socket, push in gently and turn it clockwise to lock it in place.
- Replace the top cover and secure with the screws removed previously.

REPLACING STEREO BEACON LAMP

- Disconnect AC power cord.
- Remove screws which hold top cover to the chassis and lift off the top cover.
- Pry nylon lamp holder from the lamp mount. Unsolder the leads from the lamp holder. Solder leads to rear terminals on the new lamp holder. Place new lamp holder in the mount.
- Replace the top cover and secure with the screws removed previously.

REPLACING DIAL LAMPS

- Disconnect AC power cord.
- Gently pull all knobs off the front panel control shafts. Remove the hex nuts from the control shafts and lift off the front panel.
- Snap out the defective lamp from the spring clip. Place the new lamp in the socket making sure that the unpainted side of the lamp faces the edge of the dial glass.
- Replace the front panel and secure with the hex nuts removed previously. Replace the knobs on the control shafts.

CLEANING DIAL GLASS

- Disconnect AC power cord.
- Gently pull all knobs off the front panel control shafts. Remove the hex nuts from the control shafts and lift off the front panel.
- If there are foam-cushion strips located at the ends of the dial glass, remove them.
- Loosen the screws that hold the retaining clips to the dial glass. Swing the clips aside and lift off the dial glass.
- Remove dust with a dry cloth. If you wish to clean more thoroughly, use a soap-and-water solution only, any stronger cleaning agent may damage the markings on the glass.
- Replace the dial glass and position it down and towards the left of the chassis front. Swing the retaining clips back into place and tighten the retaining-clip screws. Replace the foam-cushion strips, if removed previously.
- Replace the front panel and secure with the hex nuts removed previously. Replace the knobs on the control shafts.

CLEANING FRONT PANEL

WARNING: Use only plain lukewarm water and a freshly laundered, soft lint-free cloth to clean the front control panel.

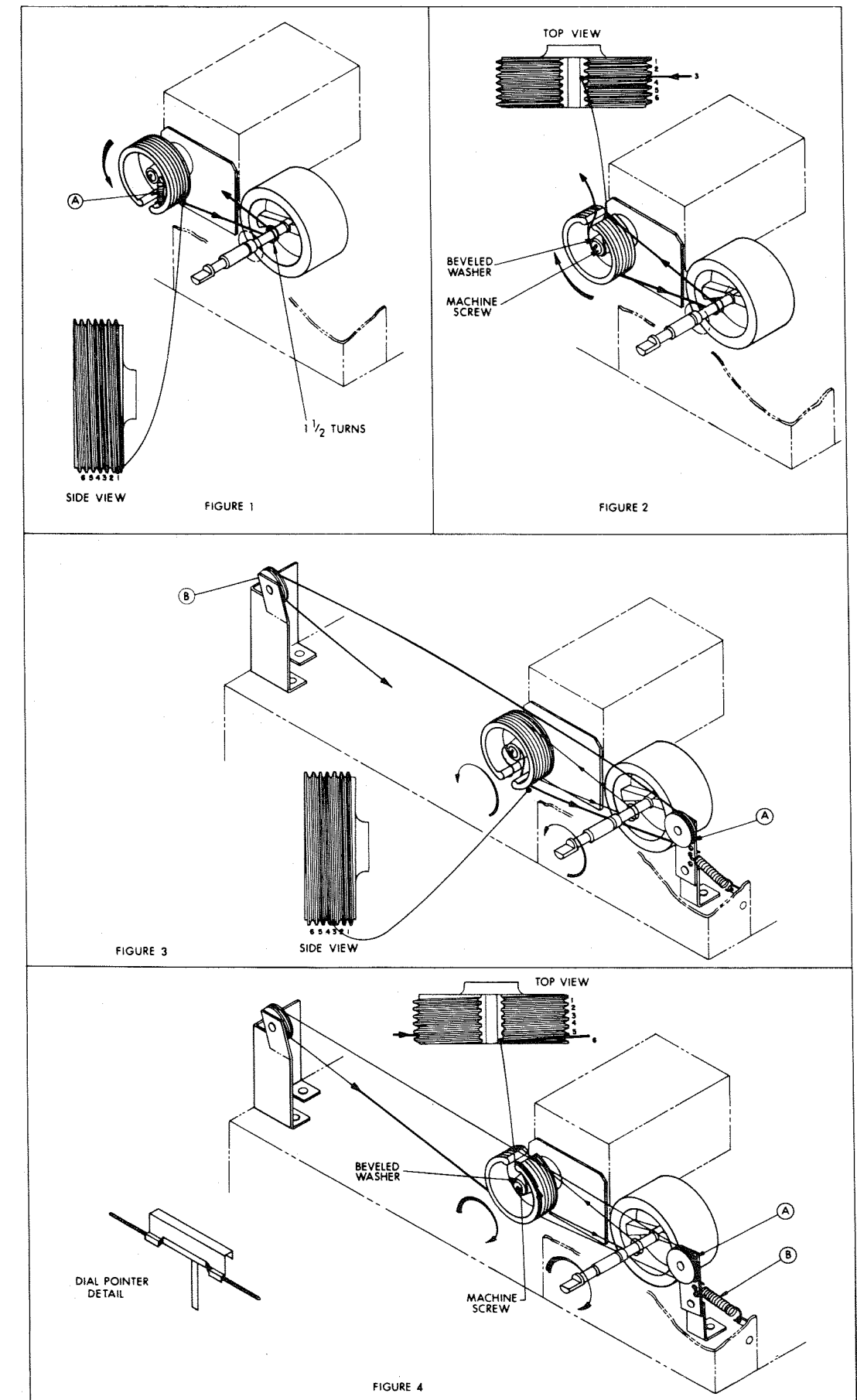

SERVICE PROCEDURES

MULTIPLEX ALIGNMENT

Two methods of aligning the multiplex decoder are given. The preferred procedure uses a multiplex generator with RF and 19 kHz (kc) outputs and with 1 kHz (kc) modulation, such as the Fisher Model 300 Multiplex Generator. This is the better method of alignment since the front end and IF stages are also checked through the use of this procedure. An alternate procedure for use with multiplex generators not having an RF output is also given.

PREFERRED ALIGNMENT PROCEDURE

Set SELECTOR switch to FM AUTO, MONO/STEREO switch to STEREO, and MUTING switch to OFF.

- Connect multiplex generator to the NORM antenna terminals. Use a 120-ohm composition resistor in series with each lead from the generator.
- Follow procedures given in Table 1 below.

NOTE: Check the alignment of the IF amplifier before aligning the MPX decoder. Poor IF alignment can make proper multiplex adjustment impossible.

ALTERNATE ALIGNMENT PROCEDURE

Set SELECTOR switch to FM AUTO, MONO/STEREO switch to STEREO, and MUTING switch to OFF.

- Disconnect lead going to connection 4P on the multiplex board. Connect multiplex generator to connection 4P through the low-pass filter shown in Figure 1.
- Follow procedures given in Table 2 below.
- After alignment, disconnect generator and low-pass filter and reconnect lead coming from connection 3K on the IF board to connection 4P on the multiplex board.

STEREO BEACON TEST

Set SELECTOR switch to FM AUTO, MONO/STEREO switch to STEREO, and MUTING switch to OFF.

- Connect FM generator to the NORM antenna terminals. Use a 120-ohm composition resistor in series with each lead from the generator.
- Modulate FM generator with 19 kHz (kc), ± 6.5 kHz (kc) deviation, from external MPX generator. Set RF generator frequency and TUNING dial pointer to 98 MHz (Mc).
- Set generator output to 2 mV; STEREO BEACON lamp should light.
- Reduce generator output to 16 μ V. Adjust Stereo Trigger Control Pot. R401 on multiplex board until STEREO BEACON lamp just lights.
- Reduce generator output to zero; STEREO BEACON lamp should go out.
- Increase generator output until STEREO BEACON lamp lights. Generator output voltage should be between 10 and 20 μ V.

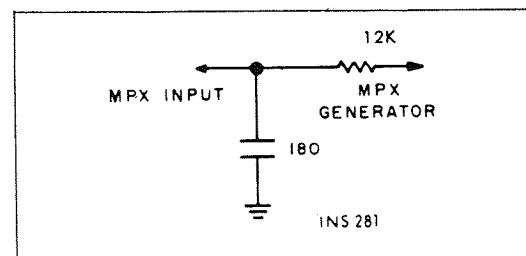

FIGURE 1. LOW-PASS FILTER CIRCUIT.

INTERMODULATION DISTORTION TEST

Set BALANCE, BASS and TREBLE controls to their center positions. Set MONO/STEREO switch to STEREO, SPEAKERS switch to MAIN and SELECTOR switch to AUX. Unplug AC power cord.

- Connect a 4-ohm, 50-watt resistor across L MAIN SPKR terminals. In parallel with the load resistor, connect the input leads of an IM (Inter-Modulation) distortion analyzer and the leads of an AC VTVM capable of reading 0.1 volts with accuracy.
- Connect IM-analyzer generator output to the L AUX jack.

NOTE: Speaker common terminals are not at ground potential. IM distortion analyzer ground should be connected to AUX input ground only.

- Connect AC power cord and rotate VOLUME control to its maximum clockwise position—full volume.
- Increase IM-analyzer generator input to set for 7 watts output (4.35 VAC across 4-ohm load resistor). AFTER ONE FULL MINUTE OF WARM-UP TIME, PROCEED TO NEXT STEP.
- IM meter reading should be 0.8% or less.
- Repeat preceding steps for the right channel.

NOTE: If any of the preceding instructions are different from those supplied with the IM-analyzer instruction manual, it is best to follow those in the manual. If a load resistor of 50-watt rating is built into the IM analyzer, a separate load resistor is not required.

HARMONIC DISTORTION TEST

Set BALANCE, BASS and TREBLE controls to their center positions. Set MONO/STEREO switch to STEREO, SPEAKERS switch to MAIN and SELECTOR switch to AUX. Unplug AC power cord.

- Connect a 4-ohm, 50-watt resistor across L MAIN SPKR terminals. In parallel with the load resistor, connect the

input leads of a harmonic distortion analyzer and the leads of an AC VTVM capable of reading 0.1 volts with accuracy.

- Connect a low-distortion audio sine wave generator, set for 1000 Hz (cps), to the L AUX jack.
- Connect AC power cord and rotate VOLUME control to its maximum clockwise position—full volume.
- Increase generator input to set for 18 watts output (8.5 VAC across 4-ohm load resistor). Harmonic distortion meter should read less than 0.8%.
- Repeat preceding steps for right channel.

POWER OUTPUT MEASUREMENT

The output amplifier of this unit is designed to deliver its full-rated power with program material (voice or music) into 4-to 16-ohm loads for indefinite periods. When a constant audio tone is used as a signal to measure the continuous RMS power output, the following precautions must be taken:

- Measure the power output of one channel at a time.
- Limit the measurement period to 10 minutes with a load resistance between 4 and 16 ohms.

If the power output of both channels must ever be measured simultaneously, use a load of 4 to 8 ohms per channel and limit measurements to a period not longer than 1 minute for a 4-ohm load and not longer than 5 minutes for an 8-ohm load.

TABLE 1 - MULTIPLEX ALIGNMENT USING RF MULTIPLEX SIGNAL

STEP	GENERATOR MODULATION	RF DEV.	INDICATOR TYPE AND CONNECTION	ALIGNMENT	
				ADJUST	INDICATION
1	70 to 76kHz (kc) (connect external audio generator to SCA input of multiplex generator).	± 25 kHz (kc)	Audio (AC) VTVM input to Test Point 404 with 10-pF capacitor in series with lead.	-	Minimum AC VTVM reading.
2	19kHz (kc) pilot only.	± 7.5 kHz (kc)	AC VTVM to Test Point 403.	Z401, 402, 403 and 404	Maximum AC VTVM reading.
3	Same as Step 3.	± 7.5 kHz (kc)	-	Trigger Control R401	Until Stereo Beacon lights up.
4	Composite MPX signal 1kHz (kc) on left channel only.	± 75 kHz (kc)	Audio (AC) VTVM and scope input to left channel output on preamp board.	Z401, 402	Maximum audio AC VTVM reading; clean 1kHz (kc) sine wave on scope.
5	Composite MPX signal 1kHz (kc) on right channel only.	± 75 kHz (kc)	Same as Step 4.	MPX Separation Control*	Minimum audio AC VTVM reading - at least 30 db below reading obtained in Step 4.
6	Same as Step 5.	± 75 kHz (kc)	Audio (AC) VTVM and scope input to right channel output on preamp board.	-	Same audio AC VTVM reading as obtained in Step 4 (± 2 db); clean 1kHz (kc) sine wave on scope.
7	Same as Step 4.	± 75 kHz (kc)	Same as Step 6.	-	Minimum audio AC VTVM reading - at least 30 db below reading obtained in Step 6.

* NOTE: Separation Control is located on preamp board.

TABLE 2 - MULTIPLEX ALIGNMENT USING COMPOSITE MULTIPLEX SIGNAL

STEP	GENERATOR MODULATION	LEVEL (RMS)	INDICATOR TYPE AND CONNECTION	ALIGNMENT	
				ADJUST	INDICATION
1	70 to 76kHz (kc) (connect external audio generator to SCA input of multiplex generator).	100mV	Audio (AC) VTVM input to Test Point 404 with 10-pF capacitor in series with lead.	-	Minimum AC VTVM reading.
2	19kHz (kc) pilot only.	50mV	AC VTVM to Test Point 403.	Z401, 402, 403 and 404	Maximum AC VTVM reading.
3	Same as Step 3.	50mV	-	Trigger Control R401	Until Stereo Beacon lights up.
4	Composite MPX signal 1kHz (kc) on left channel only.	300mV	Audio (AC) VTVM and scope input to left channel output on preamp board.	Z401, 402	Maximum audio AC VTVM reading; clean 1kHz (kc) sine wave on scope.
5	Composite MPX signal 1kHz (kc) on right channel only.	300mV	Same as Step 4.	MPX Separation Control*	Minimum audio AC VTVM reading - at least 30 db below reading obtained in Step 4.
6	Same as Step 5.	300mV	Audio (AC) VTVM and scope input to right channel output on preamp board.	-	Same audio AC VTVM reading as obtained in Step 4 (± 2 db); clean 1kHz (kc) sine wave on scope.
7	Same as Step 4.	300mV	Same as Step 6.	-	Minimum audio AC VTVM reading - at least 30 db below reading obtained in Step 6.

* NOTE: Separation Control is located on preamp board.

SERVICE PROCEDURES

FM FRONT END ALIGNMENT

NOTE: FM IF alignment must be performed before starting this procedure.

Set SELECTOR switch to FM AUTO, MONO/STEREO switch to STEREO and MUTING switch to OFF.

(1) Set TUNING dial pointer to zero (0) calibration mark on the logging scale. If the dial pointer does not coincide with the 0 at the extreme end of the knob rotation, reposition the pointer assembly on the dial cord and cement the pointer in place to prevent slippage.

NOTE: Moving dial pointer will make realignment of AM front end necessary.

(2) Connect DC VTVM to Test Point 301 on the IF board. (3) Connect an RF generator to the NORM antenna terminals. Use a 120-ohm composition resistor in series with each lead from the generator—see Figure 1.

(4) Set RF generator frequency and TUNING dial pointer to 90 MHz (Mc). DO NOT USE MODULATION (AM or FM) and keep the generator output as low as possible during the alignment procedure.

(5) Align FM oscillator coil (L503) core first—then align the FM RF coil (L502) and the FM antenna coil (L501) cores for maximum reading on DC VTVM.

(6) Set generator frequency and TUNING dial pointer to 106 MHz (Mc).

(7) Adjust FM oscillator trimmer (C518) first—then adjust the FM RF trimmer (C511) and the FM antenna trimmer (C501) for maximum reading on DC VTVM.

(8) Repeat alignment several times until accurate dial calibration and maximum gain are obtained. Keep the generator output as low as possible during all adjustments.

FM IF ALIGNMENT

Set SELECTOR switch to FM AUTO, MONO/STEREO switch to STEREO and MUTING switch to OFF.

(1) Connect 10.7-MHz (Mc) sweep generator to the NORM antenna terminals. Disconnect jumper between terminals 3F and 3G on IF board. Connect scope vertical input through 220K resistor to Test Point 301.

(2) Adjust generator output voltage and frequency to observe IF response curve. Use as low a generator output as possible during the alignment procedure. Measure voltage at Test Point 301 with DC VTVM during alignment and readjust generator output to keep meter reading between -1.4 to -2.0 VDC maximum.

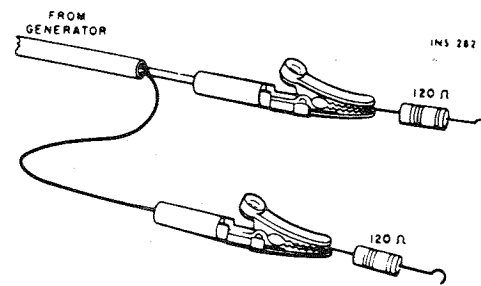

FIGURE 1. CONNECTIONS TO PROVIDE 300-OHM GENERATOR OUTPUT IMPEDENCE. MATCHING RESISTORS REDUCE GENERATOR VOLTAGE BY HALF AT THE ANTENNA TERMINALS.

(3) Detune top core of Z303 outwards. (4) Align bottom core of Z303, top and bottom cores of Z302, Z301 and L504 for maximum gain and symmetry—see Figure 2. Repeat alignment.

(5) Reconnect jumper between terminals 3F and 3G. Disconnect wire and 0.02- μ F capacitor from Test Point 302 (terminal 3N) and connect scope vertical input through 220K resistor to Test Point 302.

(6) Align top core of Z303 for maximum gain and symmetry—see Figure 3.

(7) Disconnect scope and reconnect wire and 0.02- μ F capacitor to Test Point 302. Connect DC VTVM to Test Point 302.

(8) Set generator output to 10.7 MHz (Mc) with no sweep. Vary generator voltage from minimum to maximum; reading on DC VTVM should increase with increase in signal.

(9) Connect DC VTVM across resistor R35. Vary generator voltage from minimum to maximum; reading on DC VTVM should decrease with increase in signal.

(10) Set generator voltage to 200mV. Adjust Meter Adjust Pot. R45 for tuning meter reading of 4.

(11) Connect scope vertical input through 220K resistor to terminal 3K.

(12) Set generator for sweep and adjust generator output voltage to observe ratio detector response. Use as low a generator output as possible.

(13) Adjust top and bottom core of Z304 for maximum gain; readjust top core for best linearity—see Figure 4.

FM TUNING METER CALIBRATION

Set SELECTOR switch to FM AUTO, MONO/STEREO switch to STEREO and MUTING switch to OFF.

(1) Connect an FM generator to the NORM antenna terminals. Use a 120-ohm composition resistor in series with each lead from the generator.

(2) Connect scope to L or R RCDR jack.

(3) Set FM generator frequency and TUNING dial pointer to 90 MHz (Mc). Modulate generator with 400 Hz (cps) \pm 75 kHz (kc) deviation; adjust generator frequency for equal amount of noise on both halves of the 400 Hz (cps) waveform on the scope. Use as low a generator voltage as possible.

(4) Decrease deviation to \pm 25 kHz (kc) and increase generator voltage to 100 μ V.

(5) Adjust top core of Z303 for maximum reading on tuning meter.

(6) Increase generator output to 200mV. Adjust Meter Adjust Pot. R45 for meter reading of 4.5.

FM MUTING ADJUSTMENT

Set SELECTOR switch to FM AUTO, MONO/STEREO switch to STEREO and MUTING switch to OFF.

(1) Connect an FM generator to the NORM antenna terminals. Use a 120-ohm composition resistor in series with each lead from the generator.

(2) Connect AC VTVM to LEFT or RIGHT RCDR OUT jack.

(3) Set FM generator frequency and TUNING dial pointer to 90 MHz (Mc). Set generator output to 16 μ V, \pm 22.5 kHz (kc) deviation with 400 Hz (cps).

(4) Adjust TUNING knob for maximum reading on tuning meter. Note reading on AC VTVM.

(5) Set MUTING switch to ON. Adjust Muting Adjust Pot. R42 for reading on AC VTVM 1 to 5 db lower than that previously noted.

(6) Reduce generator voltage to zero—no 400 Hz (cps) signal or noise should be indicated on AC VTVM at RCDR OUT jack.

AM FRONT END ALIGNMENT

NOTE: AM IF alignment must be performed before starting this procedure.

Set SELECTOR switch to AM.

(1) Set TUNING dial pointer to zero (0) calibration mark on the logging scale. If the dial pointer does not coincide with the 0 at the extreme end of the knob rotation, reposition the pointer assembly on the dial cord and cement the pointer in place to prevent slippage.

NOTE: Moving dial pointer will make realignment of FM front end necessary.

(2) Connect oscilloscope through 220K resistor to Test Point 2. Connect AC VTVM to Test Point 2.

(3) Connect an RF generator to RF trimmer (C6) through a 220pF capacitor; generator ground to chassis.

(4) Set RF generator frequency and TUNING dial pointer to 600 kHz (kc). Use 30% modulation with 400 Hz (cps) and keep the generator output as low as possible during the alignment procedure.

(5) Align AM oscillator coil (L2) core for maximum audio indication on oscilloscope and AC VTVM.

(6) Set RF generator frequency and TUNING dial pointer to 1400 kHz (kc). Adjust AM oscillator trimmer (C9) for maximum audio indication on oscilloscope and AC VTVM. Repeat alignment until maximum is reached.

(7) Connect RF generator to AM antenna terminal; generator ground to chassis.

(8) Set RF generator frequency and TUNING dial pointer to 600 kHz (kc).

(9) Align AM mixer coil (Z1) core and adjust position of small coil on end of ferrite loop antenna for maximum audio indication on oscilloscope and AC VTVM.

NOTE: To adjust the antenna coil, melt the wax holding the small coil to the end of the ferrite antenna. Shift the coil back and forth for maximum audio indication. Secure coil with melted wax.

(10) Set RF generator frequency and TUNING dial pointer to 1400 kHz (kc).

(11) Adjust AM mixer trimmer (C6) and AM antenna trimmer (C3) for maximum audio indication on oscilloscope and AC VTVM. Repeat alignment until maximum is reached.

AM IF ALIGNMENT

Set SELECTOR switch to AM.

(1) Connect short jumper wire between AM RF trimmer (C6) and chassis ground.

(2) Connect 455-kHz (kc) sweep generator to Test Point 1 (insulation of wire at pin 1 of Z2). Connect scope vertical input through 220K resistor to Test Point 2.

(3) Adjust generator output voltage and frequency to observe IF response curve. Use as low a generator output as possible during the alignment procedure.

(4) Align top and bottom cores of Z2, Z3 and core of L3 for maximum amplitude and symmetry—see Figure 3. Repeat alignment.

(5) Disconnect jumper between AM RF trimmer (C6) and chassis ground.

PREDRIVER/DRIVER OUTPUT ADJUSTMENT

Set BALANCE, BASS and TREBLE controls to their center positions. Set MONO/STEREO switch to STEREO, SPEAKERS switch to MAIN and SELECTOR switch to AUX. Unplug AC power cord.

(1) Connect a 4-ohm, 50-watt resistor across L MAIN SPKR terminals. In parallel with the load resistor, connect the vertical input leads of an oscilloscope.

(2) Connect an audio sine wave generator, set for 1000 Hz (cps), to the L AUX jack.

(3) Connect AC power cord and rotate VOLUME control to its maximum clockwise position—full volume.

(4) Increase generator output until sine wave on scope just starts to clip. Adjust DC Bias Adjust Pot. R302 on the left channel predriver/driver board for equal clipping on the positive and negative half cycles of the signal.

(5) Repeat preceding steps for right channel.

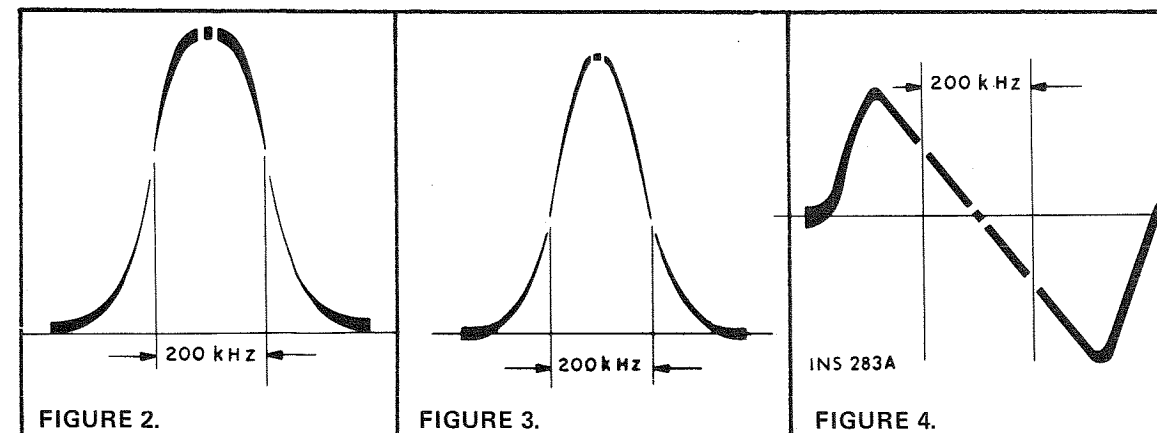

1374-5 PREDRIVER/DRIVER

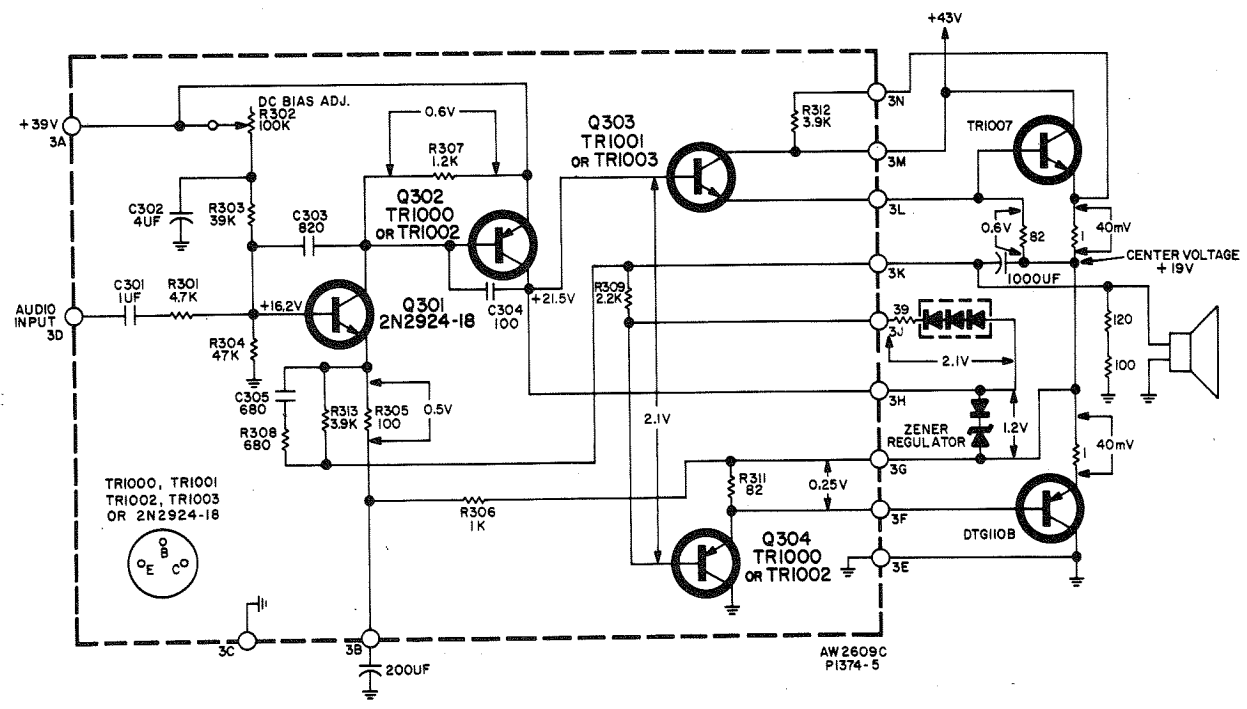

BOARD VIEWED FROM THE COMPONENT SIDE

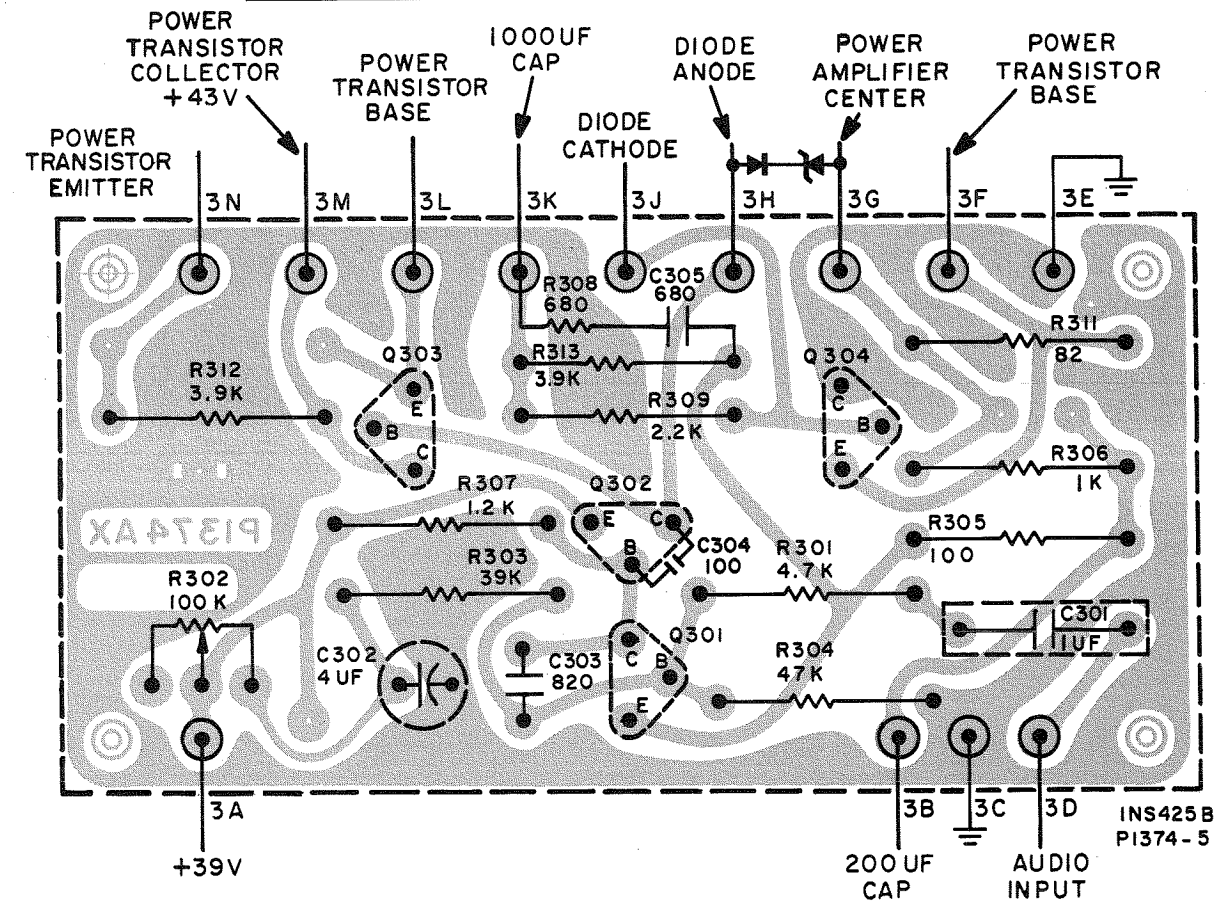

1398-2 PREAMPLIFIER

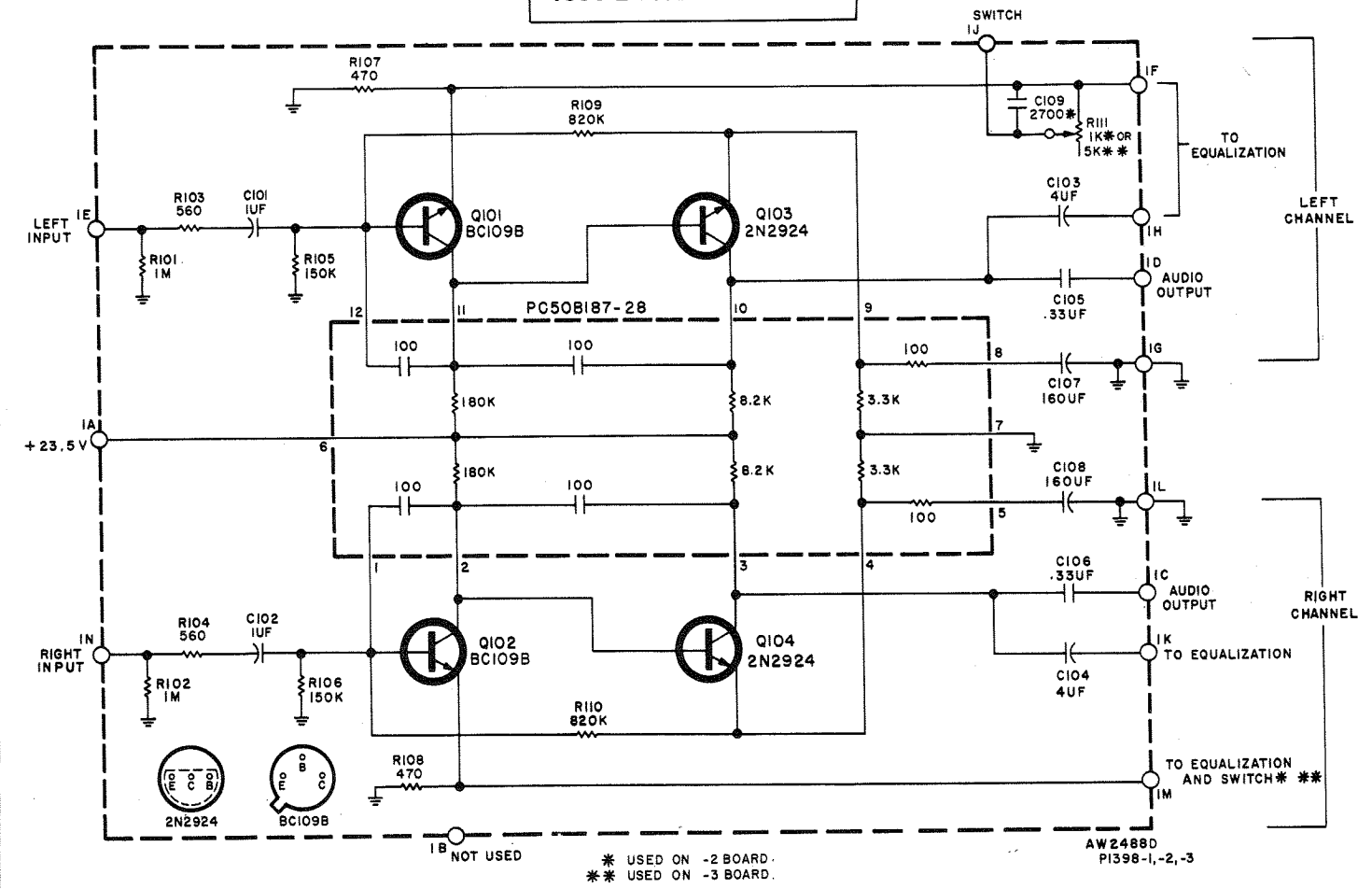

BOARD VIEWED FROM THE COMPONENT SIDE

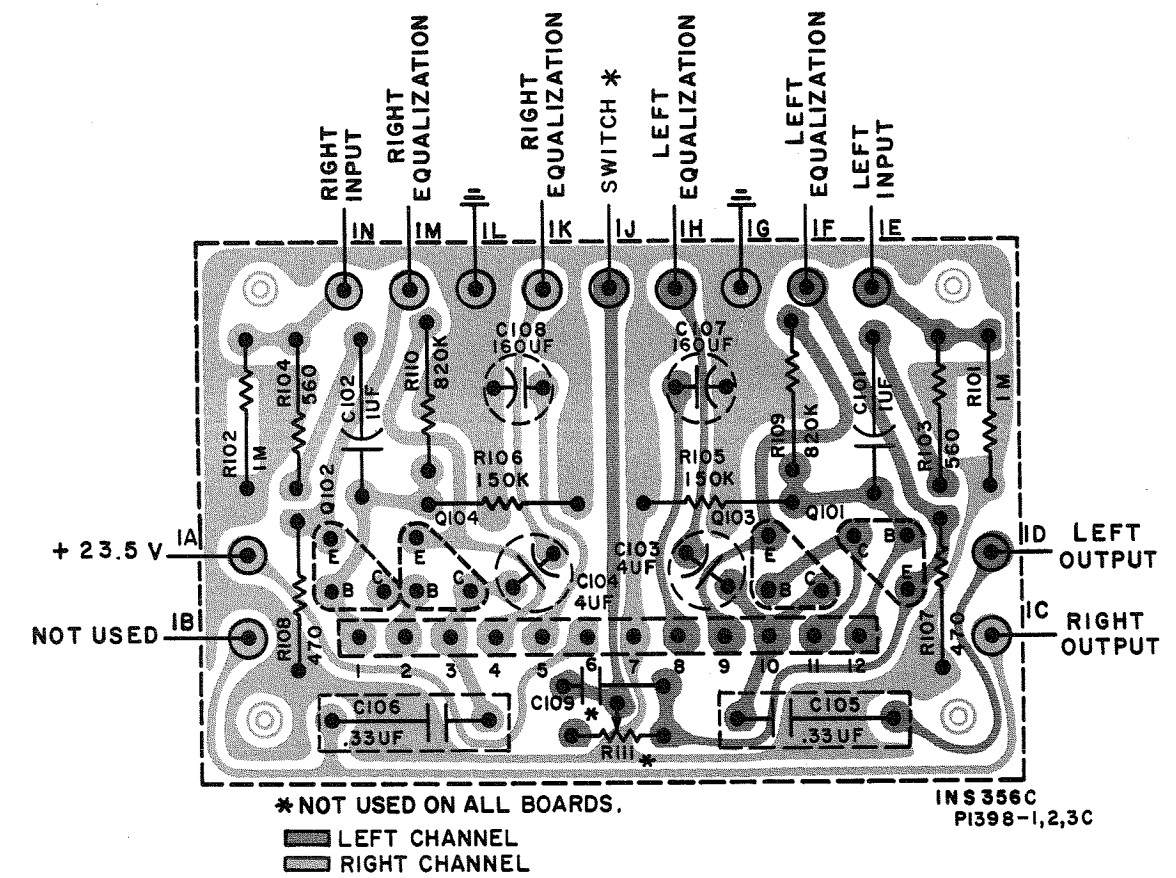

1263 AM-FM FRONT END

PI263 AM-FM FRONT END

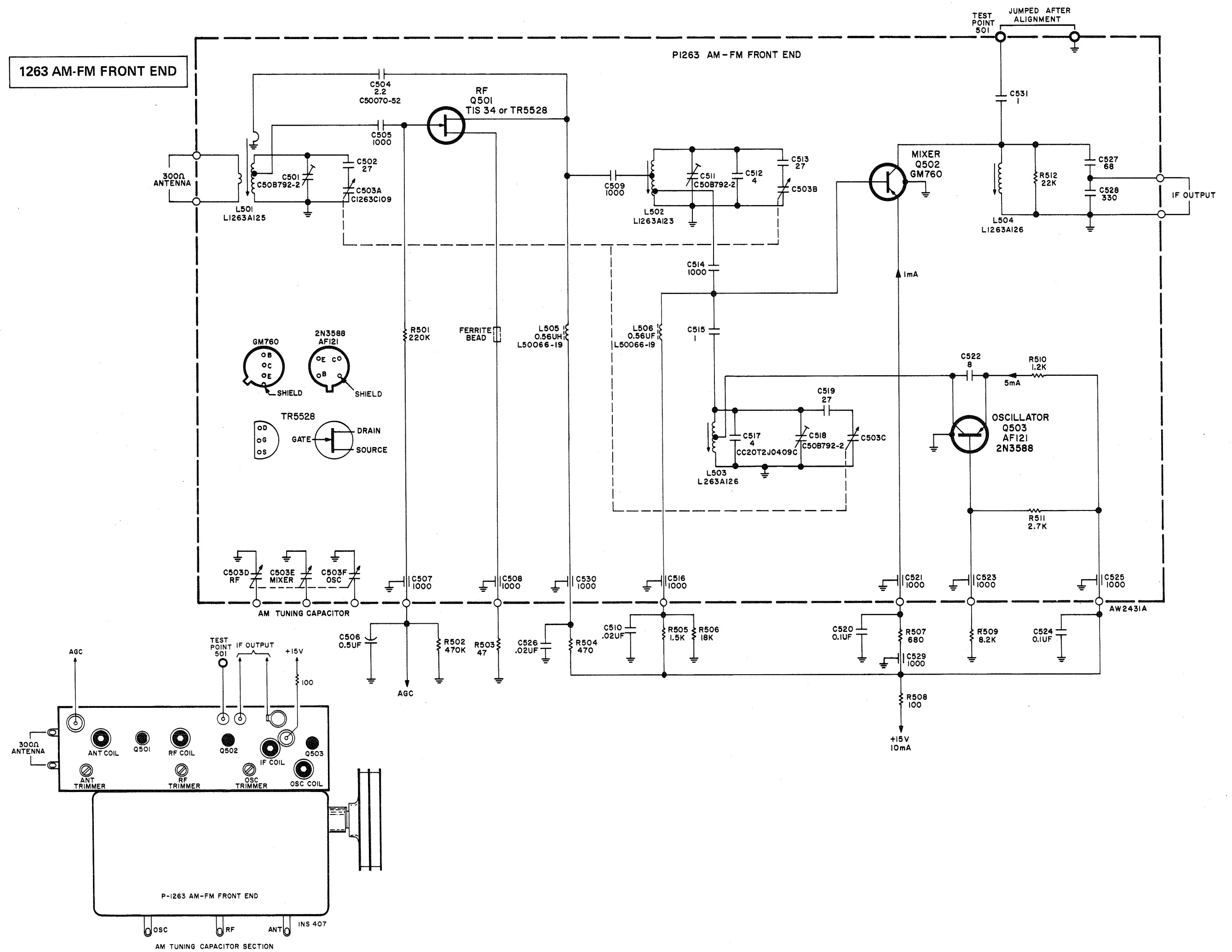

1381-1 10.7 MHz IF AMPLIFIER

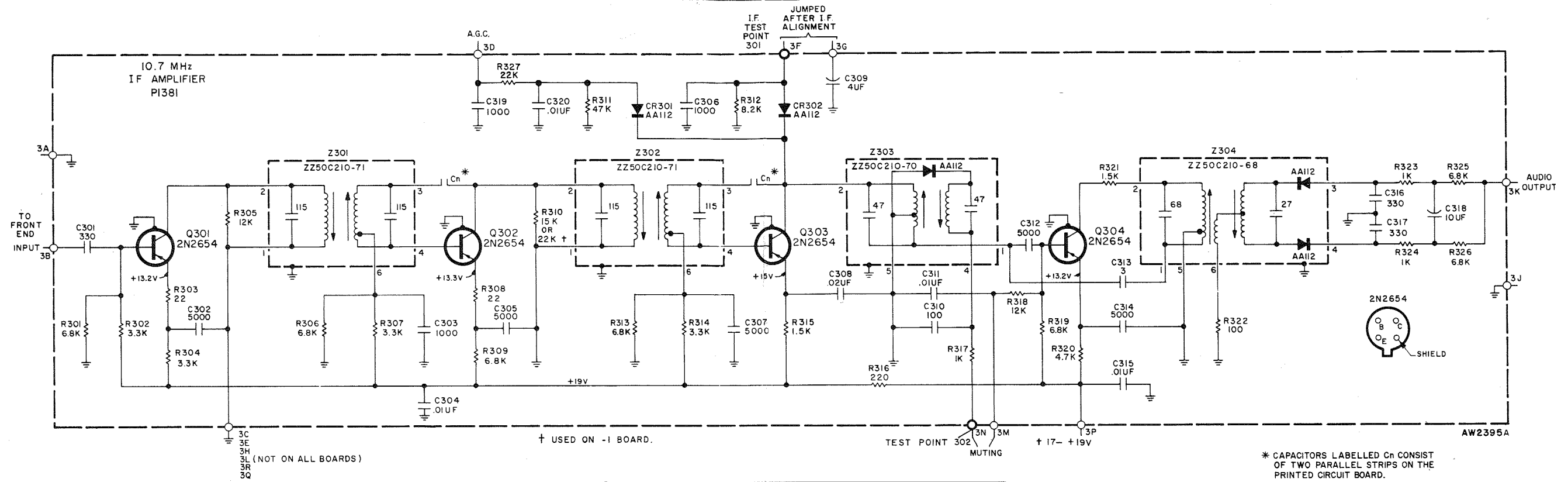

BOARD VIEWED FROM THE COMPONENT SIDE

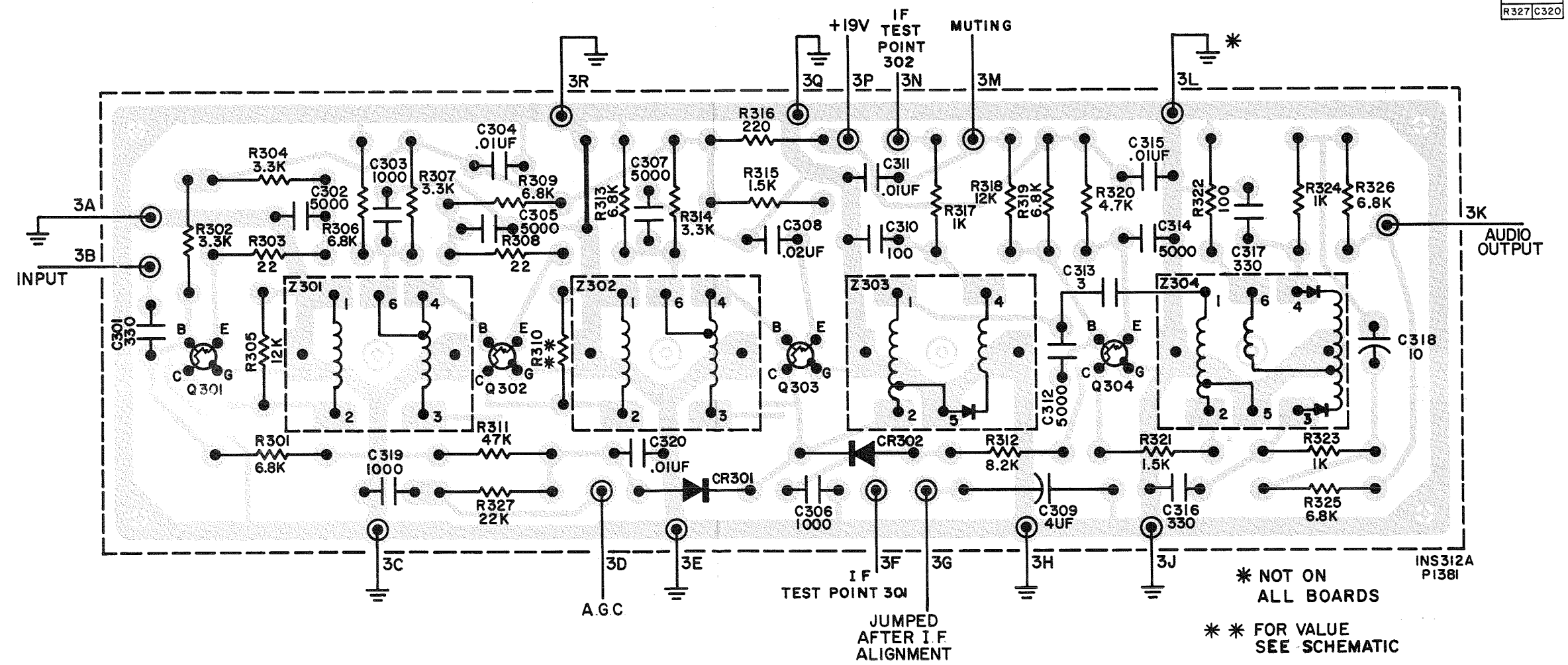

LAST
R327 C320

1242-1 MULTIPLEX DECODER

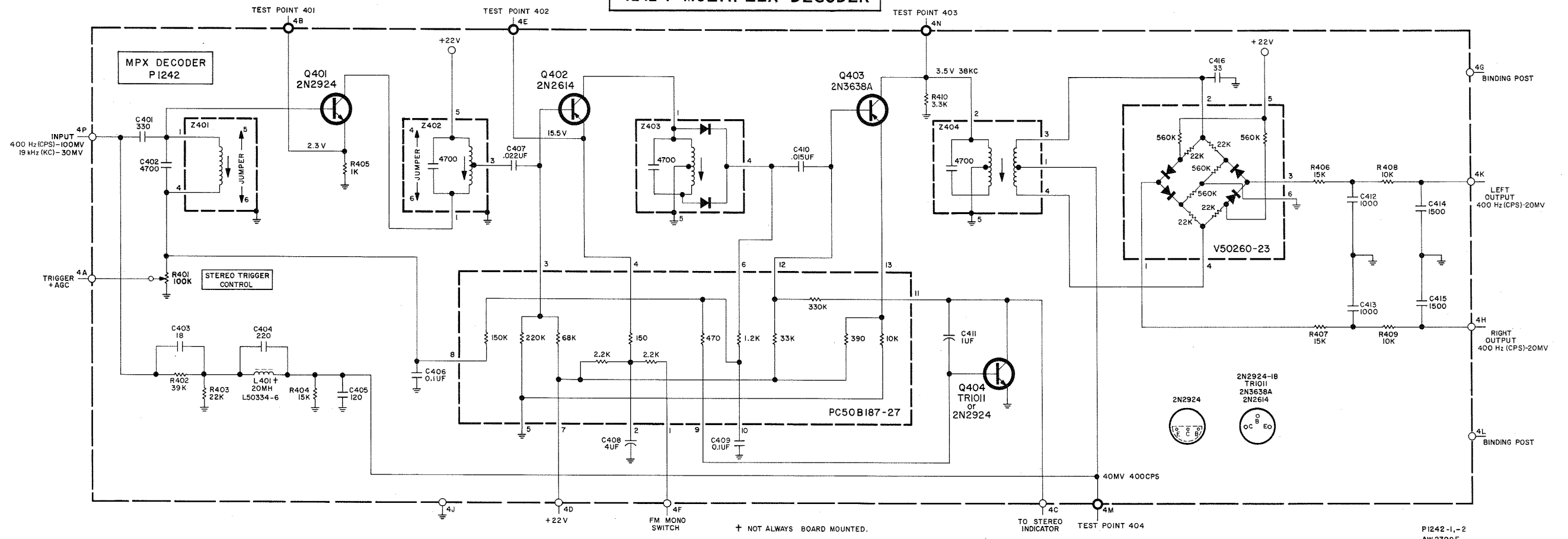

BOARD VIEWED FROM THE COMPONENT SIDE

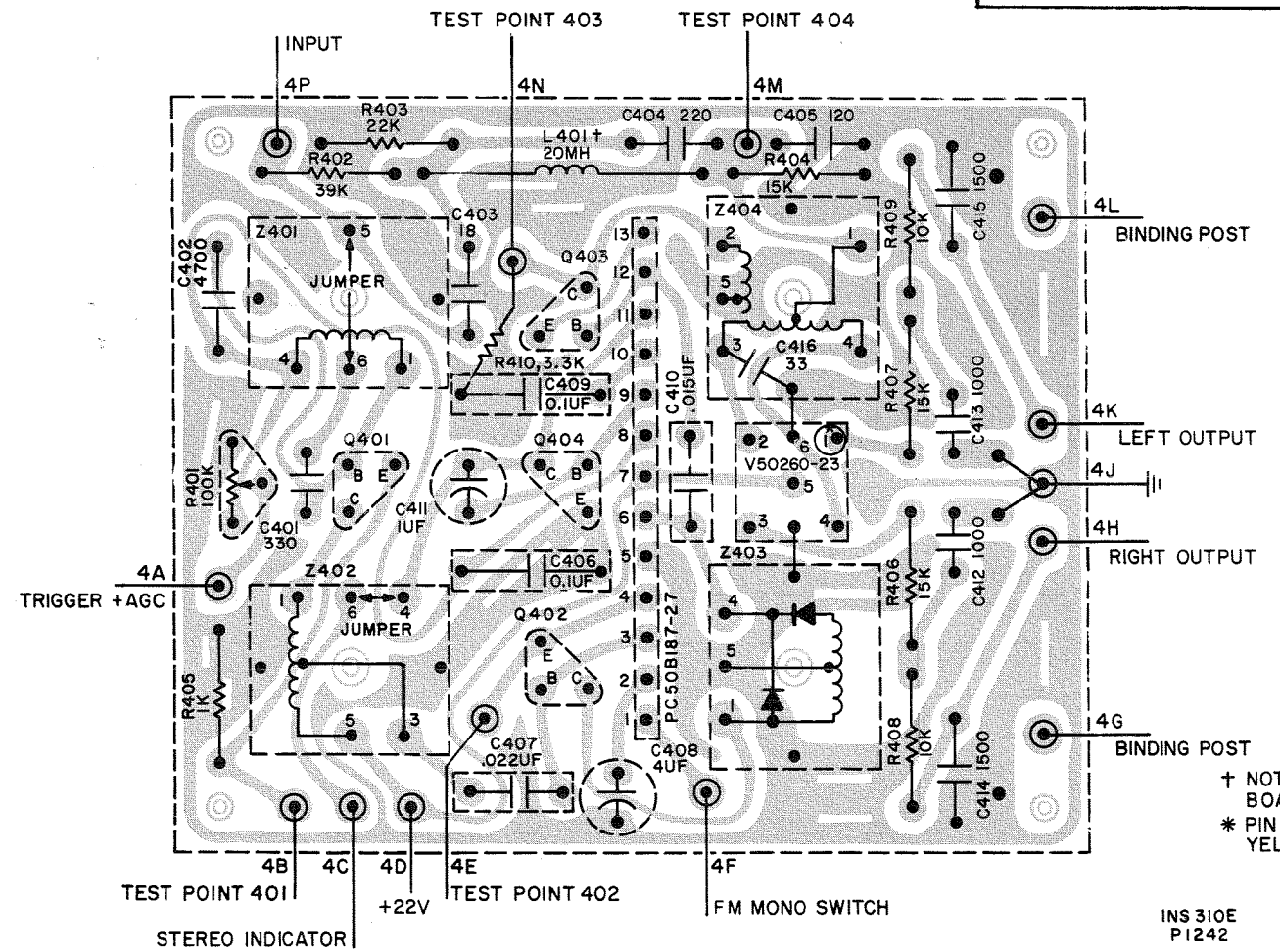

MAIN CHASSIS-TUNER SECTION

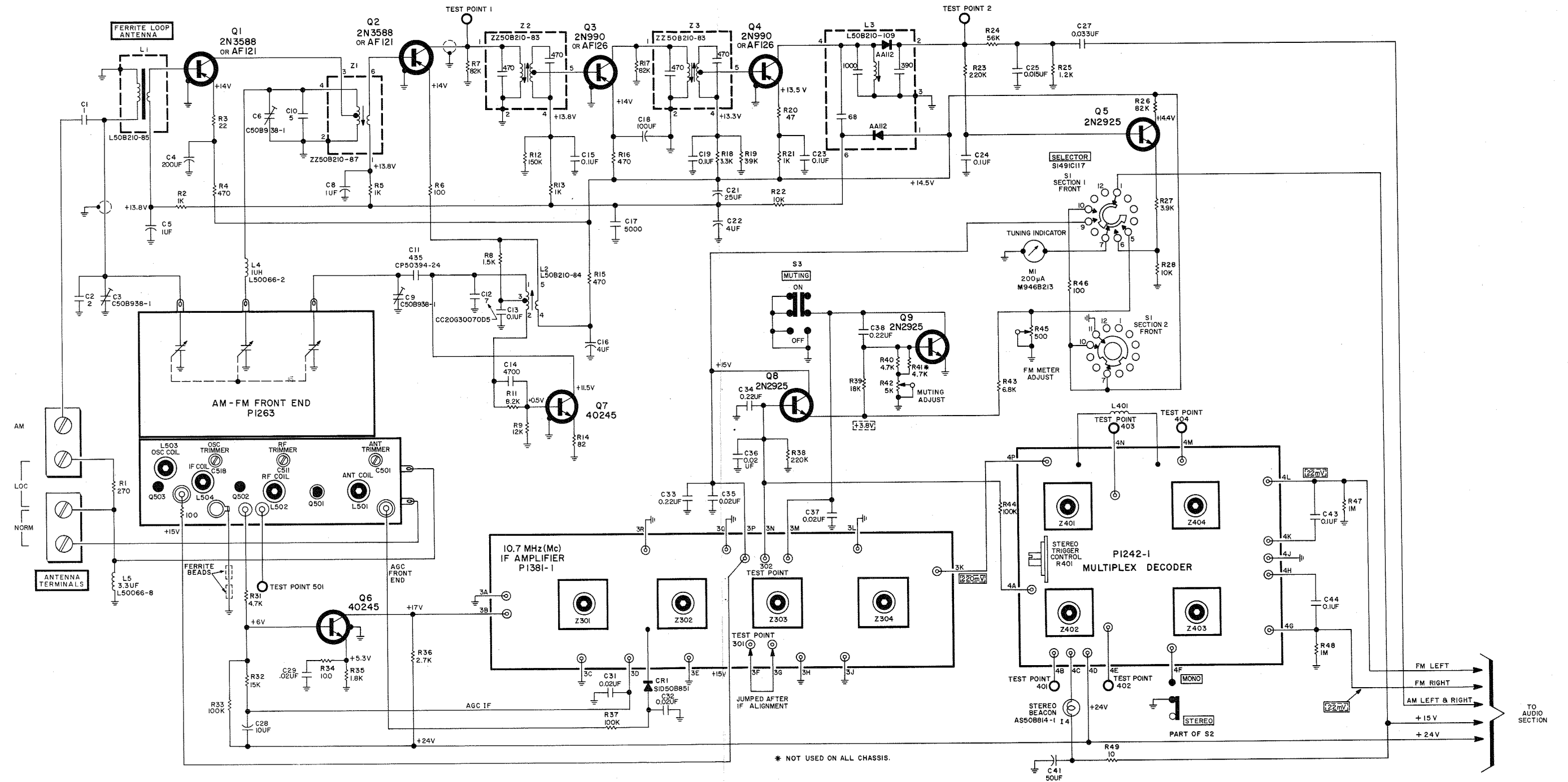

COMPONENT CONNECTIONS

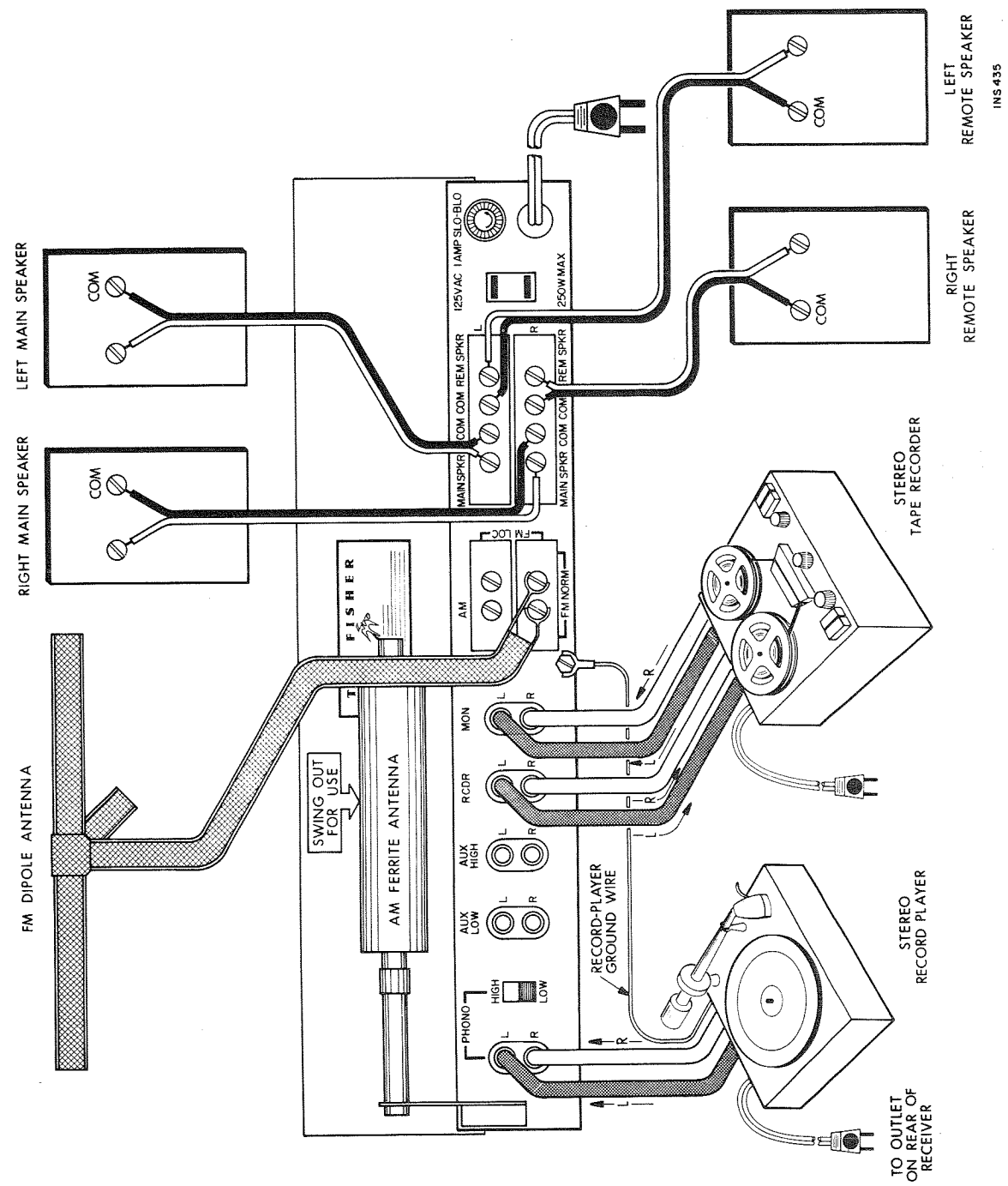

CHASSIS LAYOUT

TOP

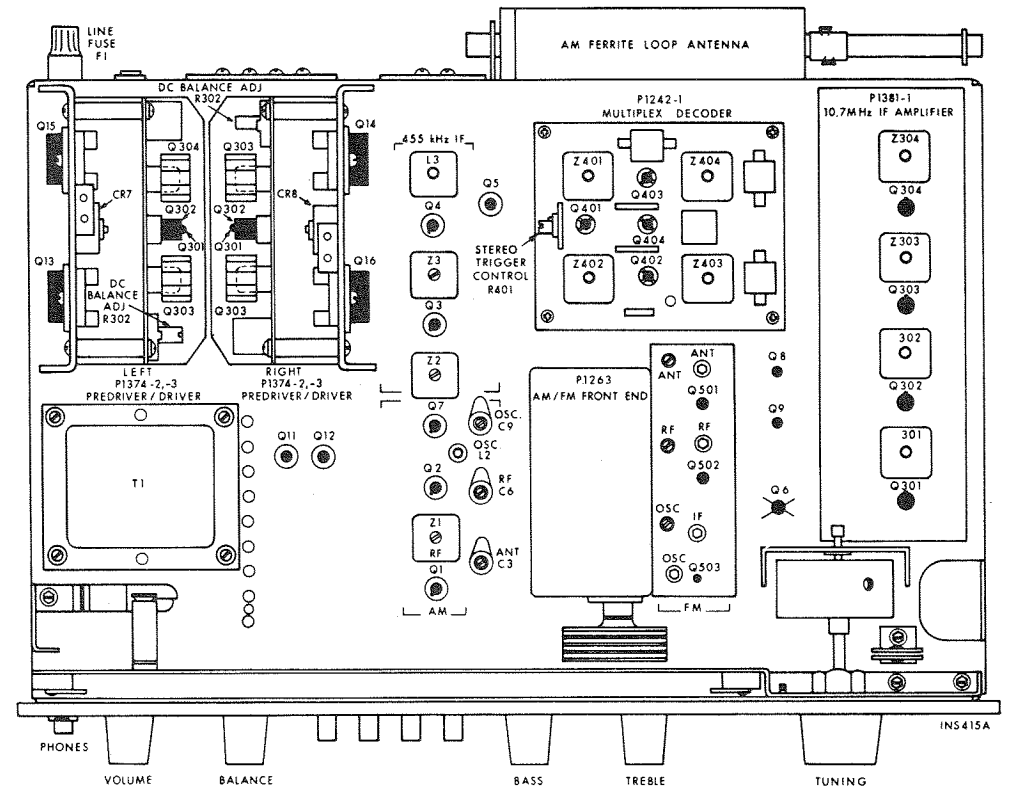

BOTTOM

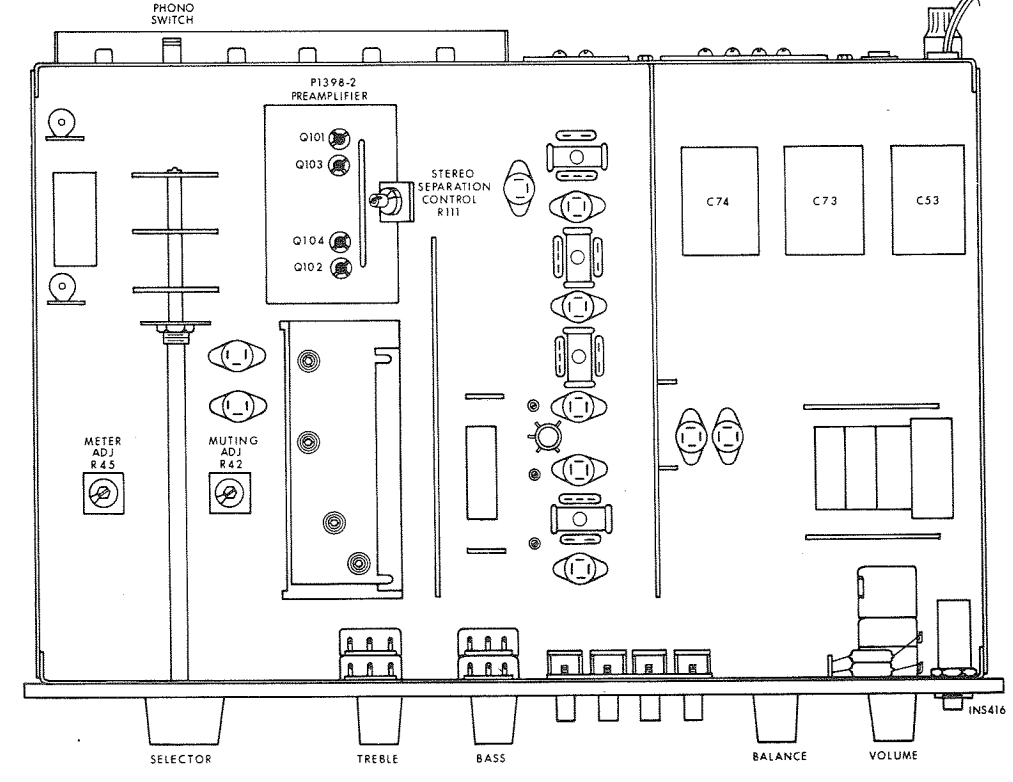

FISHER RADIO CORPORATION • NEW YORK